

# Oven

## User manual

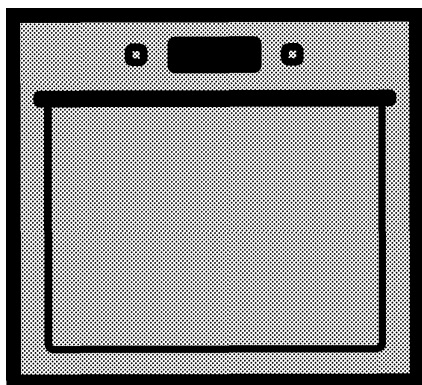

# Description of your oven

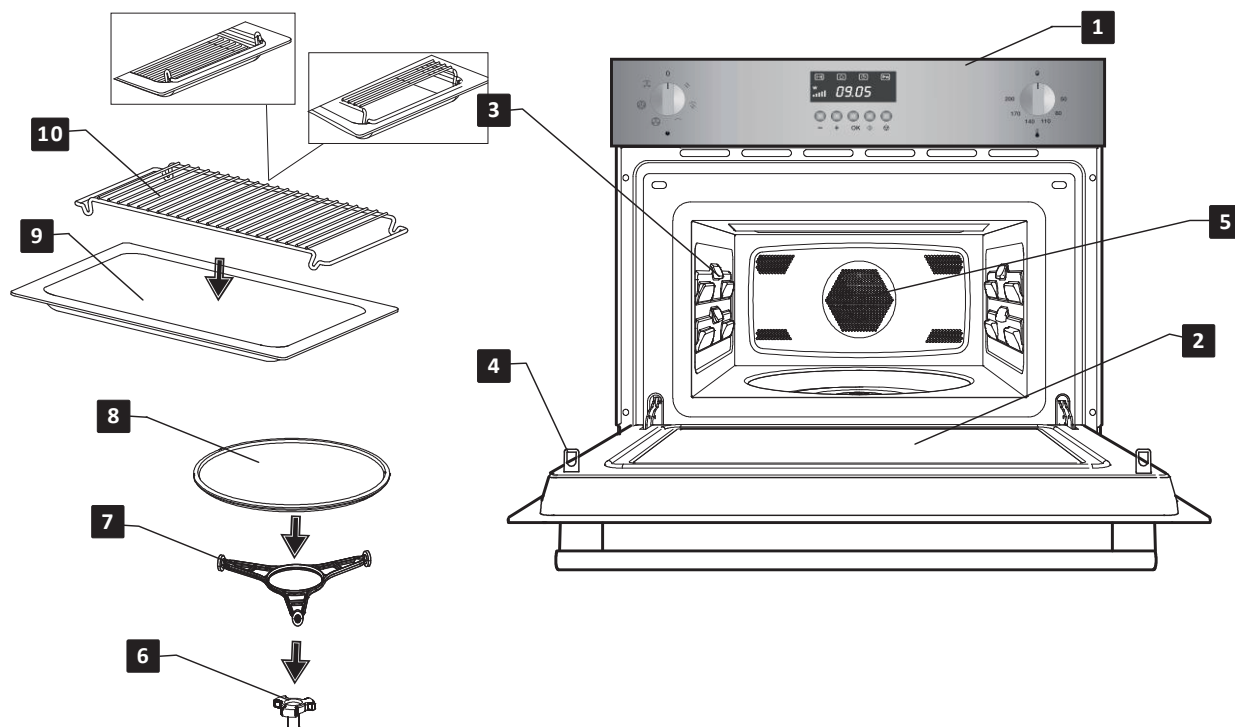



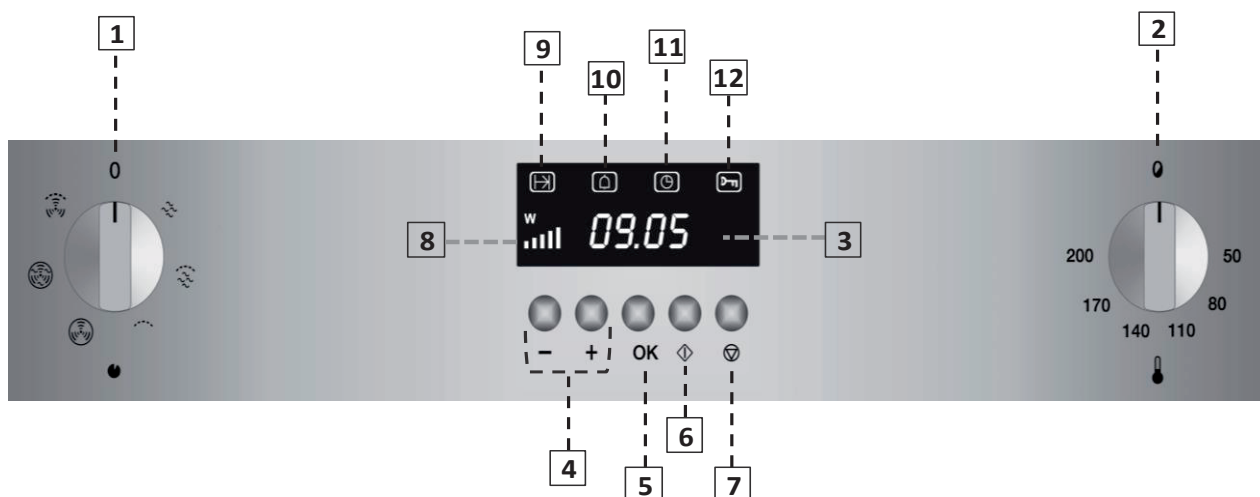



- |                            |                                 |
|----------------------------|---------------------------------|
| <b>1</b> Control panel     | <b>6</b> Turntable support      |
| <b>2</b> Door window glass | <b>7</b> Turntable ring         |
| <b>3</b> Lateral supports  | <b>8</b> Turntable plate        |
| <b>4</b> Catches           | <b>9</b> Rectangular Glass tray |
| <b>5</b> Hot Air Output    | <b>10</b> Rectangular Rack      |



- |                             |  |
|-----------------------------|--|
| <b>1.</b> Function Selector | <b>7.</b> Stop key                       |
| <b>2.</b> Thermostat        | <b>8.</b> Power level indicator light    |
| <b>3.</b> Display           | <b>9.</b> Operating time indicator light |
| <b>4.</b> "+" and "-" keys  | <b>10.</b> Timer indicator light         |
| <b>5.</b> OK key            | <b>11.</b> Clock indicator light         |
| <b>6.</b> Start key         | <b>12.</b> Child lock indicator light    |

# Description of your oven

## Description of Functions

Function	Microwaves Power	Foods	
	Microwave	200 W	Slow defrosting for delicate foods; keeping food hot
		400 W	Cooking with little heat; boiling rice. Rapid defrosting
		600 W	Melting butter. Heating baby food
		800 W	Cooking vegetables and food. Cooking and heating carefully. Heating and cooking small portions of food. Heating delicate food
		1000 W	Cooking and rapidly heating liquids and pre-cooked foods
	Microwaves + Grill	200 W	Toasting food
		400 W	Grilling poultry and meat
		600 W	Cooking pies and cheese-topped dishes
		800 W	Use carefully: food might burn.
		1000 W	Use carefully: food might burn.
	Grill	---	Grilling food
	Microwaves + Hot-Air	200 W	Meat roast and simmer
		400 W	Poultry roast
		600 W	Other fast roasts
		800 W	Use carefully: food might burn.
		1000 W	Use carefully: food might burn.
	Hot-Air	---	Roast and bake
	Grill + Fan	---	Food even browning

## Basic settings

### Setting the clock

After your microwave oven is first plugged-in or after a power failure, the clock display will flash to indicate that the time shown is not correct. Before using the microwave oven, adjust the clock through the procedure described below but starting on Step 3.

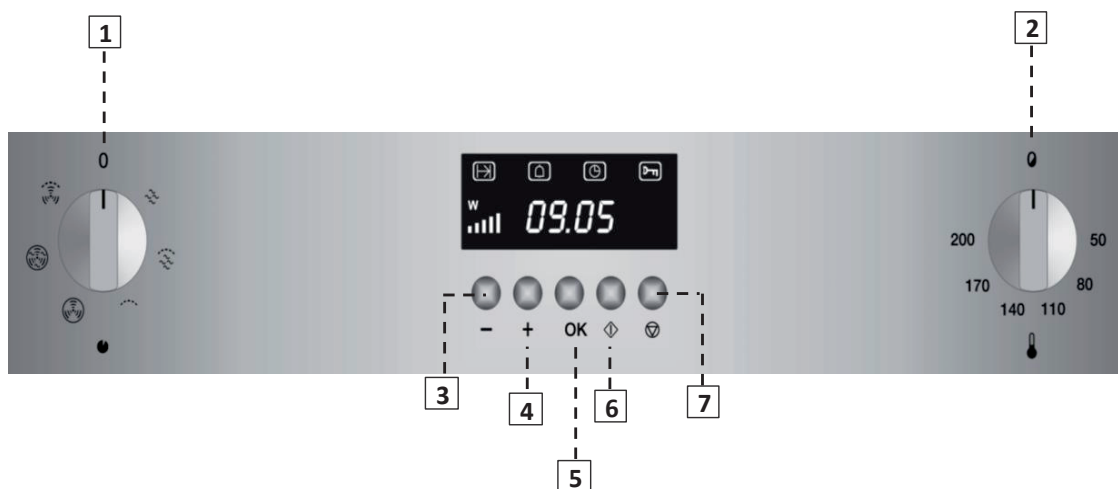

To set the clock, proceed as follows:

1. Press the “+” (4) key until the **Clock Indicator Light** starts to flash.
2. Press the **OK (5) key**.
3. Press “+” (4) and “-” (3) keys to set the correct hour value.
4. Press the **OK (5) key** to validate the hour value. The minute numbers will start to flash.
5. Press “+” (4) and “-” (3) keys to set the correct minute value.
6. To finish, press the **OK (5) key** again.

### Hiding/Displaying the Clock

If the clock display disturbs you, you can hide it.

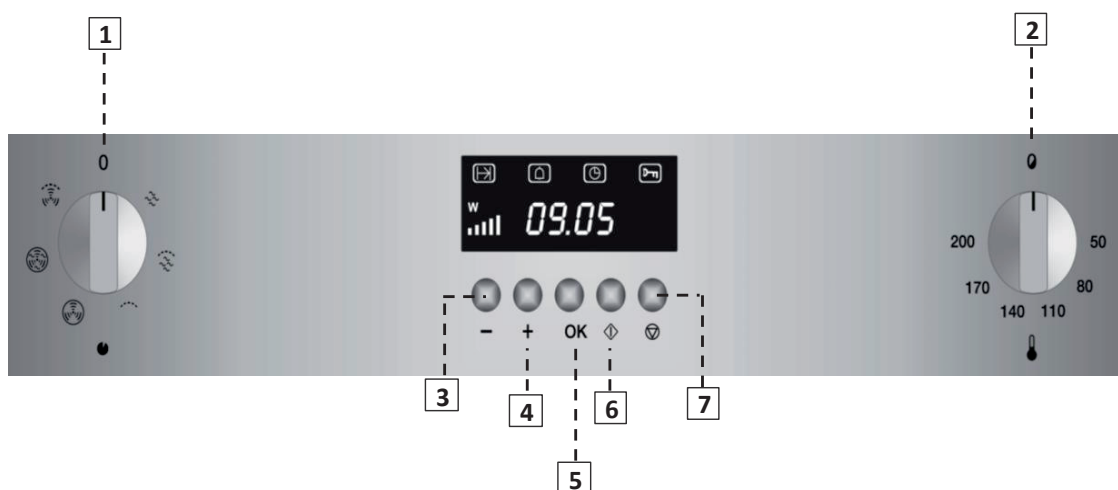

1. Press the “+” (4) and “-” (3) keys simultaneously for 3 seconds. The dots that separate the hours and minutes will flash but the rest of the clock display will be hidden.
2. If you want to see the clock again, press the “+” (4) and “-” (3) simultaneously again for 3 seconds.

## Basic settings

### Child lock

The oven functioning can be blocked (for example to stop it being used by children).

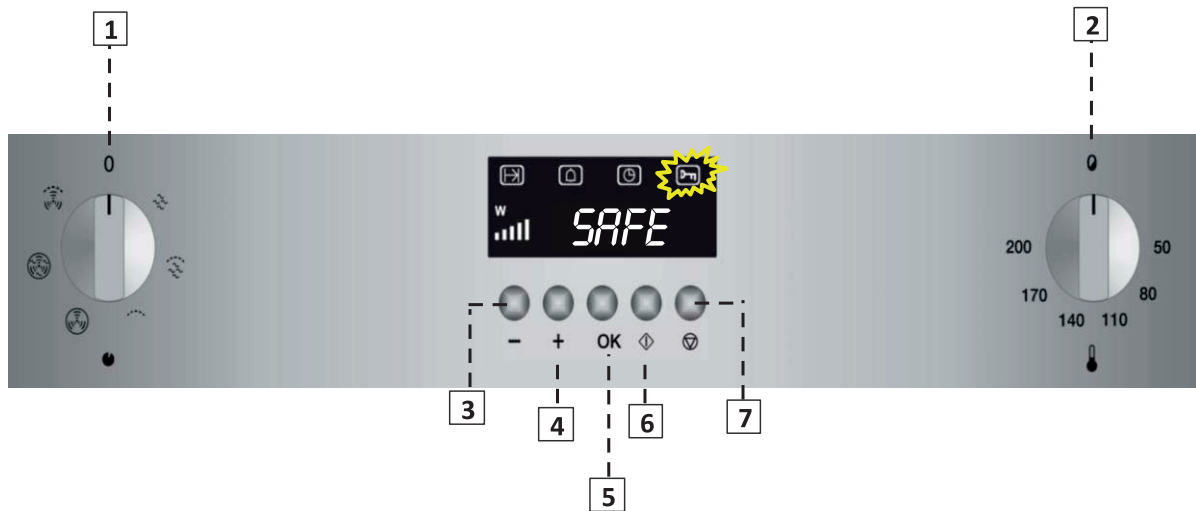

1. To Block the oven, press the **Stop** key (7) for 3 seconds. When a key is pressed the display shows a Key symbol and the oven performs no function.

2. To unblock the oven press again the **Stop** key (7) for 3 seconds.

 The oven's display does not show the internal temperature reached. Depending on the chosen temperature, a preheating period from 15 to 25 minutes is recommended.

### Timer

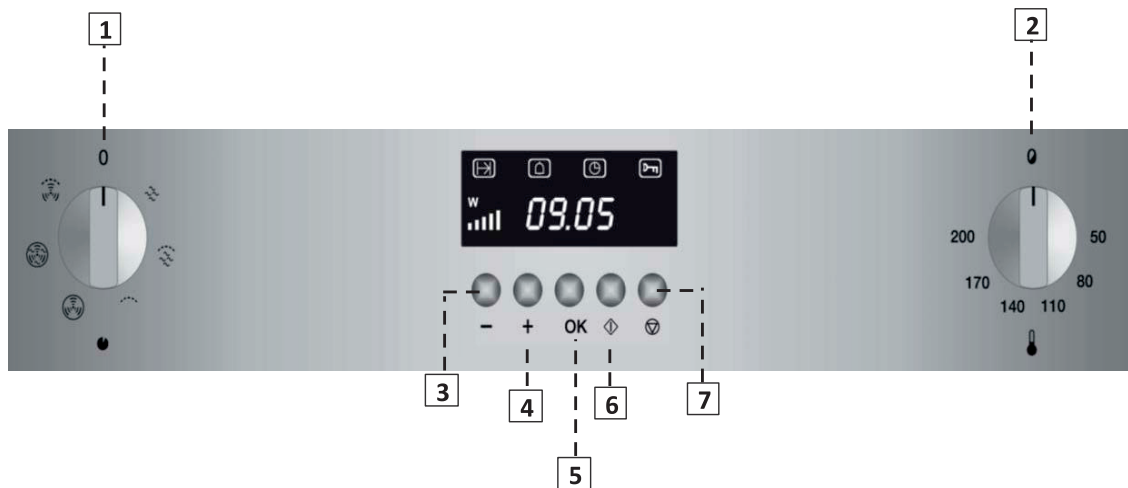

1. Press the “+” key (4) until the **Timer** indicator flashes.  
 2. Press the **OK** key (5).  
 3. The numbers flash. Press the “+” (4) and “-” (3) keys to set the desired time.

4. Press the **OK** key (5). The timer will countdown to zero and at the end of the set time the oven will sound 3 beeps every 30 seconds until the **OK** key (5) is pressed.

To cancel the active Timer function repeat the above steps but setting the time to zero

## Basic Functions

### Microwaves

Use this function to cook and heat vegetables, potatoes, rice, fish and meat.

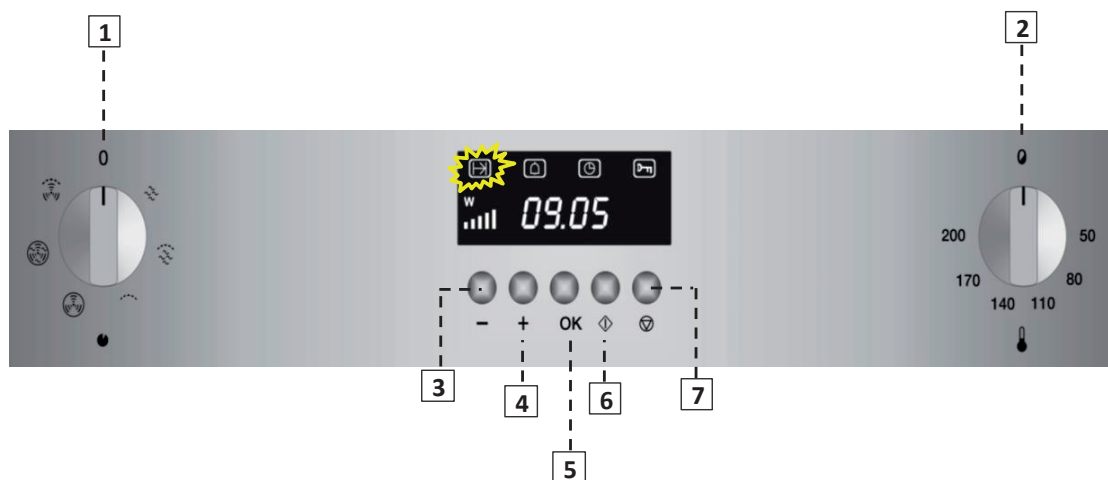

1. Rotate the **Function Selector (1)** to the position corresponding to the Microwave Function



2. The **Operating Time Indicator Light** flashes.

3. Press the **OK key (5)**.

4. Using the “+” (4) and “-” (3) keys set the desired operating time.

5. Press the **OK key (5)**.

6. The **Power Level Indicator Light** will start to flash.

7. Using the “+” (4) and “-” (3) keys set the required microwave power level.

8. Press the **OK key (5)**.

9. Press the **Start key (6)**. The oven will start to operate.

### Grill

Use this function to brown the top of food quickly.

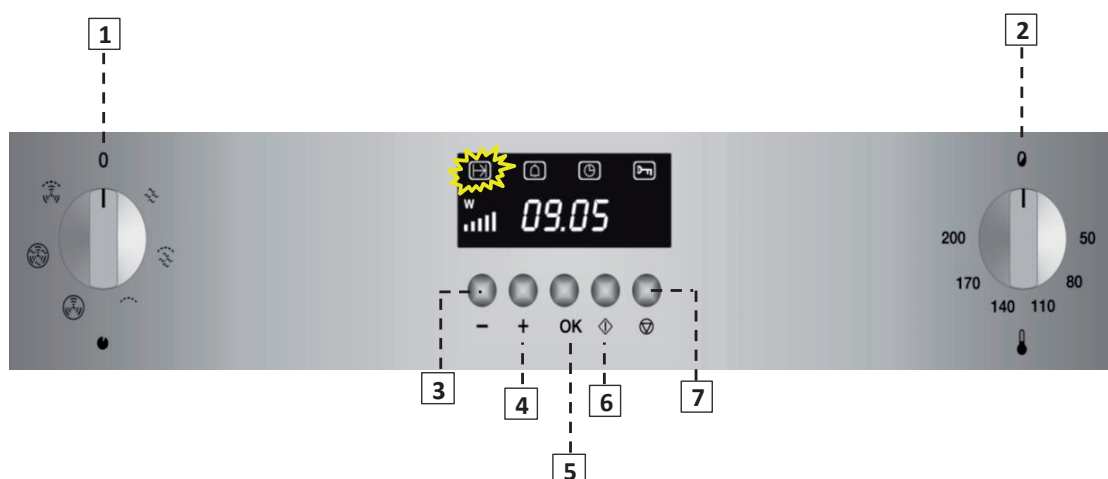

1. Rotate the **Function Selector (1)** to the position corresponding to the Grill Function.



2. The **Operating Time Indicator Light** and the **Display** start to flash.

3. With the “+” (4) and “-” (3) keys set the desired operating time.

4. Press the **OK key (5)**.

5. Press the **Start key (6)**. The oven will start to operate.

## Basic Functions

### Microwaves + Grill

Use this function to cook lasagne, poultry, roast potatoes and toasted foods.

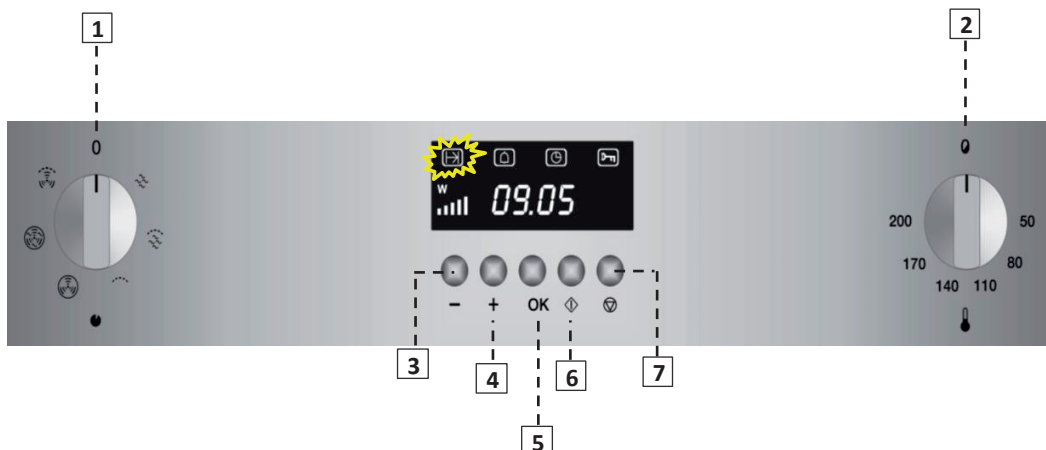

1. Rotate the **Function Selector (1)** to the position corresponding to the Microwave + Grill



Function.

2. The **Operating Time Indicator Light** will flash and the **Power Level Indicator Light** will be on. The operating time will flash in the display.
3. With the “+” (4) and “-” (3) keys set the desired operating time.

4. Press the **OK key (5)**.

5. The **Power Level Indicator Light** will flash.

6. Using the “+” (4) and “-” (3) keys select the required microwave power level.

7. Press the **OK key (5)**.

8. Press the **Start key (6)**. The oven will start to operate.

### Hot-Air

Use this function to bake food.

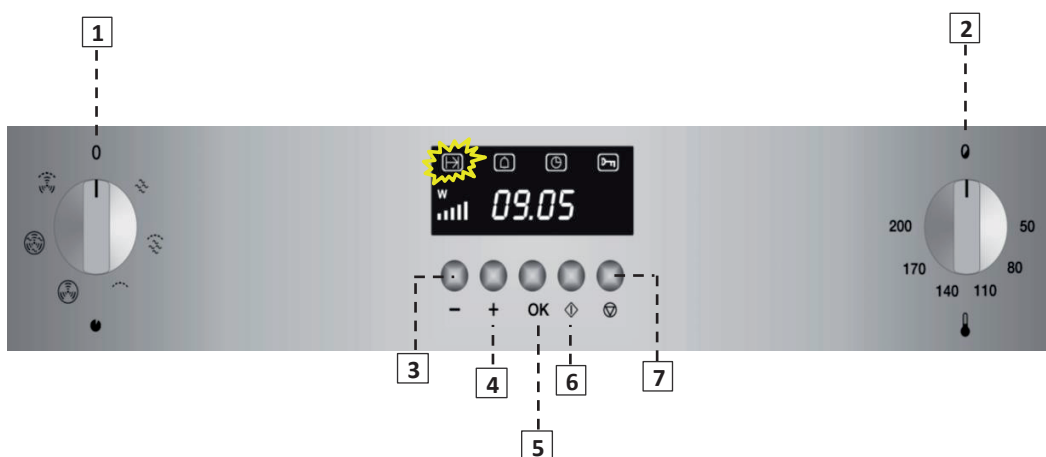

- 1 Rotate the **Function Selector (1)** to the position corresponding to the Hot-Air Function.



2. The **Operating Time Indicator Light** and the **Display** start to flash.

3. With the “+” (4) and “-” (3) keys set the desired operating time.

4. Press the **OK key (5)**.

5. Select the desired oven temperature using the **Thermostat control (2)**.

6. Press the **Start key (6)**. The oven will start to operate.

## Basic Functions

### Microwaves + Hot-Air

Use this function to rapidly bake the foods.

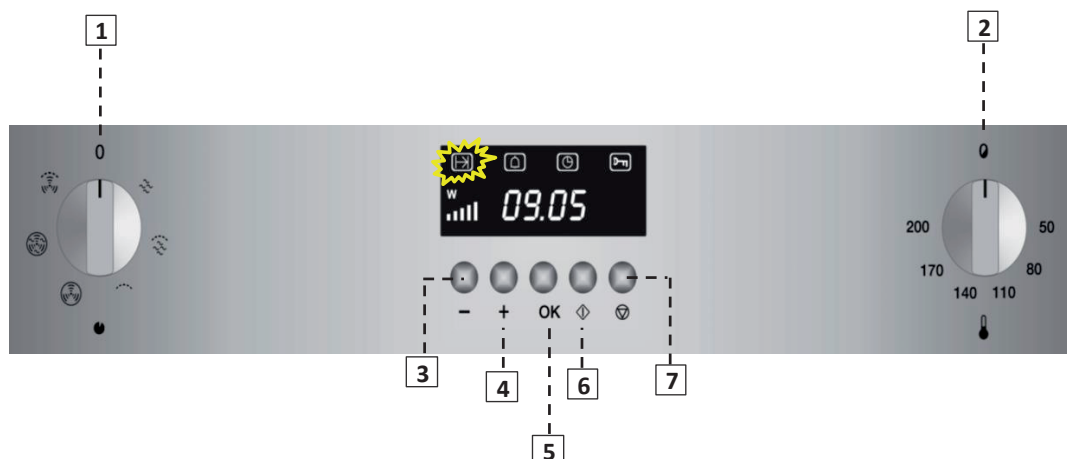

1. Rotate the **Function Selector (1)** to the position corresponding to the Microwave + Hot-



Air Function.

2. The **Operating Time Indicator Light** will flash and the **Power Level Indicator Light** will be on. The operating time will flash in the display.
3. With the “+” (4) and “-” (3) keys set the desired operating time.
4. Press the **OK key (5)**.
5. The **Power Level Indicator Light** will flash.
6. With the “+” (4) and “-” (3) keys set the desired microwave power level.
7. Press the **OK key (5)**.
8. Select the desired oven temperature using the **Thermostat control (2)**.
9. Press the **Start key (6)**. The oven will start to operate.

### Grill + Fan

Use this function to bake evenly the food and at the same time brown their surface.

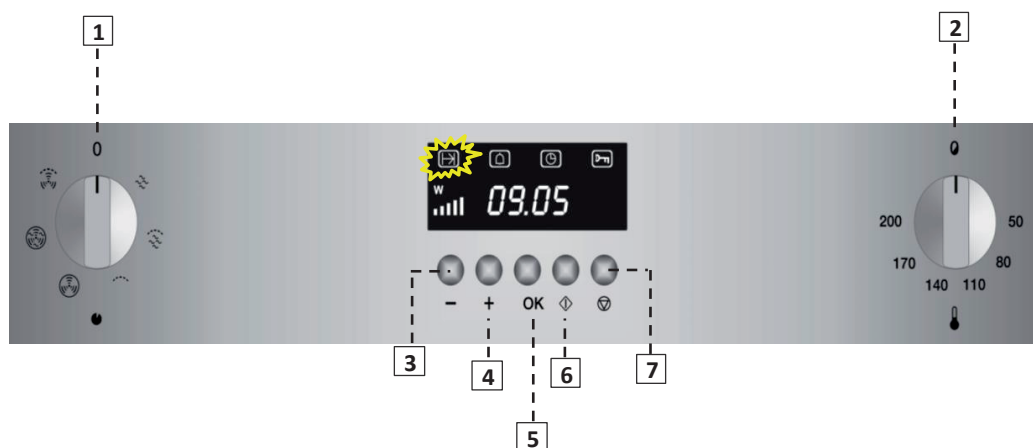

1. Rotate the **Function Selector (1)** to the position corresponding to the Grill + Fan



Function.

2. The **Operating Time Indicator Light** and the **Display** start to flash.
3. With the “+” (4) and “-” (3) keys set the desired operating time.
4. Press the **OK key (5)**.
5. Press the **Start key (6)**. The oven will start to operate.



## Basic Functions

### Defrosting by time (manual)

Use this function to defrost any type of food quickly.

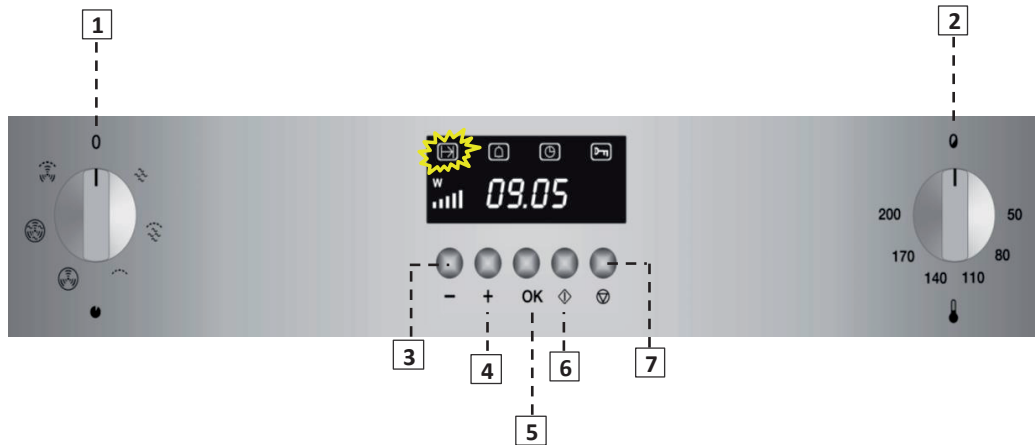

1. Rotate the **Function Selector (1)** to the position corresponding to the Microwave Function



2. The **Operating Time Indicator Light** flashes.

3. Press the **OK key (5)**.

4. Using the “+” (4) and “-” (3) keys set the desired operating time.

5. Press the **OK key (5)**.

6. The **Power Level Indicator Light** will start to flash.

7. Using the “+” (4) and “-” (3) keys set the required microwave power level.

8. Press the **OK key (5)**.

9 Press the **Start key (6)**. The oven will start to operate.